

# SmartShelter Container

## 96kW/50Hz All In One Datacenter Module

### Technical Specification

Version 2.0

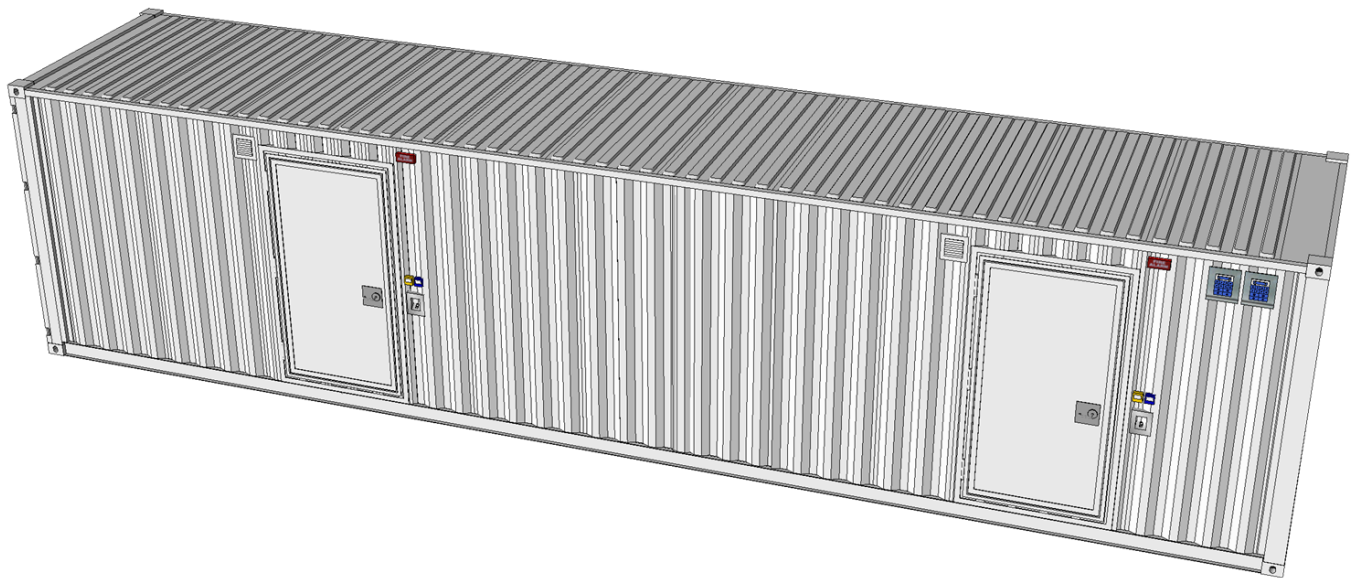

# Table of Contents

1	Introduction.....	4
1.1	Context .....	4
1.2	Main benefits .....	4
1.3	Scope of work .....	4
2	Prefabricated Datacenter Module .....	5
2.1	Introduction .....	5
2.2	Concept and Dimensions for Prefabricated Module .....	5
2.2.1	Prefabricated Solution for 12 Racks with UPS .....	5
2.3	Structural design .....	6
2.3.1	ISO shipping container .....	6
2.3.2	Wall design .....	6
2.3.3	Floor .....	7
2.3.4	Doors .....	7
2.3.5	Cable Glands.....	8
2.3.6	Air Renovation System (optional).....	8
2.4	Technical Specifications .....	9
2.4.1	Shock-load.....	9
2.4.2	Wind load.....	9
2.4.3	Roof load .....	9
2.4.4	Floor load.....	9
2.4.5	External temperature range.....	9
2.4.6	Internal environmental conditions.....	9
2.4.7	Fire resistance .....	9
2.4.8	Painting.....	9
2.5	Mounting Pad support.....	9
2.6	Lifting elements.....	10
3	Electrical System .....	10
3.1	Components .....	10
3.2	Grounding .....	11
4	Fire Suppression System.....	11
4.1	Fire Control Panel.....	11
4.2	Smoke Detector .....	12
4.3	Extinguishing system .....	12
4.3.1	IG-55.....	12
5	Monitoring System (optional).....	13
5.1	Struxeware DC Expert (optional).....	13
5.2	Environmental Monitoring .....	14
6	Internal Module Components and Design.....	14

6.1	Uninterruptible Power Supply (UPS) .....	15
6.2	Racks.....	15
6.2.1	Cable Management .....	16
6.2.2	Rack Power Distribution .....	16
6.2.3	Rail System .....	17
6.3	Room Power Distribution .....	17
6.4	Cooling.....	17
7	Exclusions .....	18

# 1 Introduction

## 1.1 Context

The purpose of the document is to introduce and present the technical specification of the SmartShelter Container 96 KW All In One Datacenter Module offered by Schneider Electric.

SmartShelter Container solution provides a fully functional Data Center inside a regular ISO container with complete infrastructure including: cooling, power, structural protection, fire protection, monitoring, access control, etc., within a secure environment design, comprising a modular and flexible approach.

This solution consists of a constructive solution of equivalent quality to a proper room dedicated to IT, including the entire necessary infrastructure.

The environment has been designed to provide the following qualities:

- Usability for IT and technical operations
- Security: Mechanical, Electrical, Cooling
- High quality, robust structure
- Reduced time to acquire and deploy

## 1.2 Main benefits

Prefabricated Datacenter Modules are the latest trend in the datacenter industry intended to decrease the time to acquire and deploy new datacenter capacity, improve the predictability and reliability of a new datacenter build and reduce upfront and ongoing capital expenditures.

All equipment in the proposed module are pre-installed and tested in our factories, reducing on-site construction risks and reducing time allocated for site works and commissioning.

Schneider Electric is a market leader in the data center business worldwide with complete integrated solutions including prefabricated modules, electrical distribution, cooling and IT space. Our installed base gives us a thorough knowledge of data center market evolution, future needs and an understanding of business challenges.

## 1.3 Scope of work

### **This proposal covers a complete prefabricated module**

This document mainly covers the following topics:

- Enclosure structure and design
- UPS
- Electrical distribution
- Cooling
- IT Infrastructure (Racks, rack and row level power distribution)
- Fire suppression and detection
- Monitoring (optional)

## 2 Prefabricated Datacenter Module

### 2.1 Introduction

The following proposal is for an All-In-One prefabricated IT Module that is a separate prefabricated structure. This module provides the complete functionality for a 96kW Datacenter environment providing power, cooling, and access for an IT environment.

### 2.2 Concept and Dimensions for Prefabricated Module

#### 2.2.1 Prefabricated Solution for 12 Racks with UPS

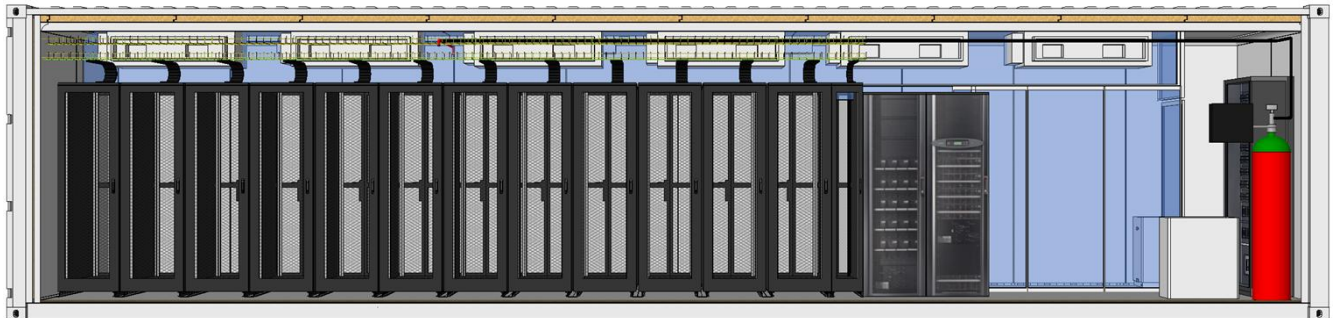

Solution for 12 racks includes:

- 1 x ISO Container: 40' (12.2m) x 8' (2.4m) x 9.5' (2.9m) (LxWxH)
- Uninterruptible Power Supply – Symmetra PX 96kW (N+1)
- Busbar Canalis KN 160A, distributing power from UPS to each IT rack.
  - Input Voltage 400 VAC, Output Voltage 400 VAC
- Electrical configuration
  - General power, lights and HVAC on non-critical power
  - IT racks on UPS power.
- Cooling
  - (6) Overhead fancoils Mitsubishi Electric SPEZ-250, N+1 configuration
  - (6) External condensers rated for -5°C to 46°C ambient
  - Optional low ambient temperature kit available temperatures down to -15 °C
  - Humidifier with controller
- Racks – NetShelter SX Enclosures
  - (12) AR3100 NetShelter SX, 600x1070x2000 (WxDxH),
- Metered Rack PDU – (12) AP8853 Rack PDU, Metered, Zero U, 32A, 230V, (36)C13 & (19)C19
- Netbotz 570 environmental monitoring system monitoring the following
  - Internal temperature
  - Internal humidity
  - Leak detection
  - External Door Status
  - Security camera monitoring

- Automatic fire extinguishing system
- Cable glands for power, refrigerant piping, and fiber entrance into the module

**Options:**

- Automatic transfer switch included for generator input as optional
- Struxureware DC Expert Basic for overall Datacenter Monitoring

## 2.3 Structural design

The SmartShelter Container is made of an external ISO 40' High Cube container with insulated panels inside. It combines the strength, resistance and protection of the ISO container with the special features of the insulated panels to provide the right Data Center environment.

### 2.3.1 ISO shipping container

The ISO shipping container is a standard 40', durable closed steel box constructed for heavy loads that can be easily handled and moved. The external height of a Standard High Cube shipping container is 9 ft. 6 in. (2896mm). It has lockable double doors on one end.

### 2.3.2 Wall design

SmartShelter Container offers high levels of thermal and fire protection. Rockwool panels close the area inside the container providing a clean area proper for a DC.

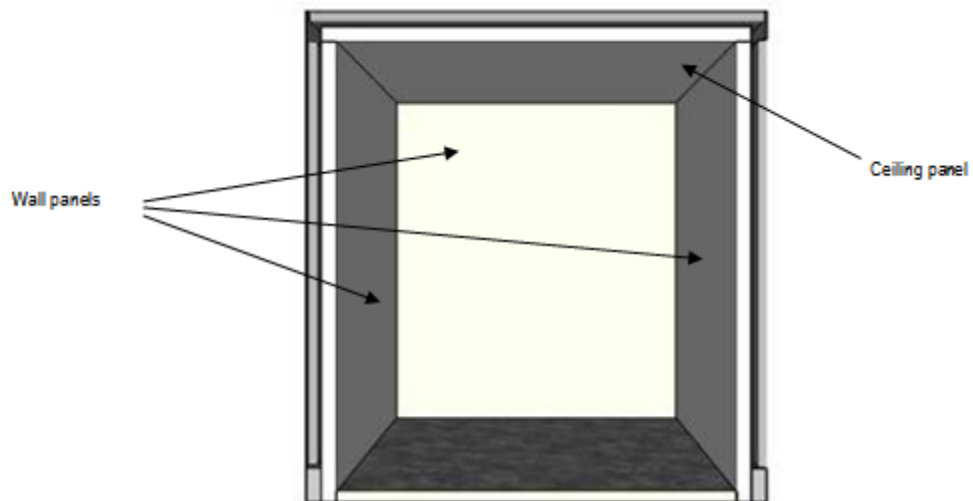

Panels will be installed on the walls and ceiling and will be composed by a sandwich of materials with fire resistance and thermal insulating to resist high temperatures and provide a watertight enclosure. The sandwich will be covered by one layer of galvanized steel sheet (0,6 mm), joined by continuous weld panel to panel.

**Main features:**

- Thickness: 60 mm
- Weight: 15,4 kg/m<sup>2</sup>
- Thermal resistance, K1 (panel): 0,592 W/m<sup>2</sup>K
- K2 (container + panel): 0,402 W/m<sup>2</sup>K
- Fire resistance: EI60

<b>Final Inner dimensions</b> <sup>(1)</sup>	Imperial	Metric
Length	465"	11.800 mm
Width	87"	2.200 mm
Height	102"	2.600 mm

<sup>(1)</sup> 2% tolerance

**2.3.3 Floor**

The 40' ISO container is equipped with 1- 1/8" (28.6 mm) thick marine plywood flooring on the interior. The finished floor is metal diamond plate.

**2.3.4 Doors**

The SmartShelter Container includes one EI 120 standard door. This door fulfills all regular requirements and requirements as an emergency exit. It is made of steel and is painted and protected against rust.

All Doors supplied with:

<b>LEAF</b>	
Steel plate finishes	1,2 mm
High-density fiberboard for fire protection with EI 120	60 mm
<b>Total thickness</b>	<b>63 mm</b>
<b>FRAMEWORK</b>	
Steel profile	1,5 mm
Intumescent seal	1,9 mm
<b>FITTINGS &amp; MECHANISMS</b>	
Steel bearing hinges	3 u
PVC & steel handle with lock door	
Electric strike	
Quick push panic bar	
Self closing system	

**Dimensions:**

	Width		Height
	Simple door	Double door	
<b>External dimensions</b>	1.280 mm 50,4"	1.740 mm 68,5"	2.380 mm 93,7"
<b>Internal dimensions</b>	1.100 mm 43,3"	1.600 mm 63"	2.200 mm 86,6"

**2.3.5 Cable Glands**

Roxtec cable glands will be installed at all cabling and piping interface points that enter or exit the module. Cable glands provide thermal, fire, and water protection for the module. The cable gland is easily configurable to adapt to the number and dimensions of cables and pipes that enter the module since it uses a compression unit inside of frame.

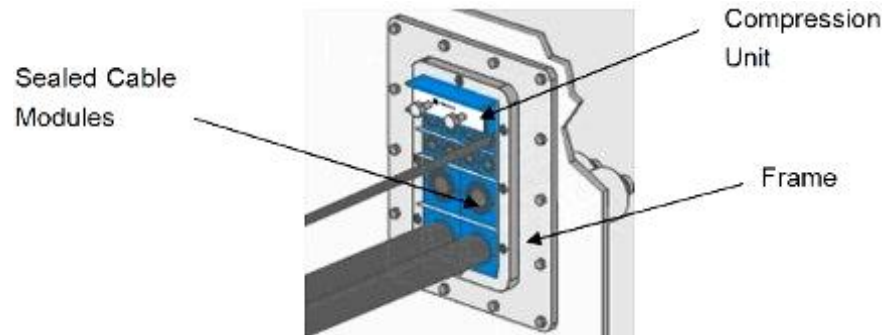

**2.3.6 Air Renovation System (optional)**

The Air Renovation System (ARS) is a ventilation unit designed to meet air renovation requirements to comply with local regulations in containerized Data Centers where IT equipment and UPS batteries are installed.

In order to provide the proper airflow, an EC fan intakes outside air via a grille attached to G4 and G7 filters. In accordance with ASHRAE, IT spaces require air filtering (minimum F7 / MERV13).

UNIT COMPONENTS	ARS (CE)
EC Radial fan	✓
Air filter G4 efficiency (MERV 8)	✓
Air filter F7 efficiency (MERV 13)	✓
Air filter F9 efficiency (MERV 16) <sup>(1)</sup>	optional
Sand trap	optional
Electrical heater (antifreeze)	optional
Timer	optional
Door switch	optional
VOC control (Volatile organic compound)	optional
H <sub>2</sub> control sensor	optional
Combined H <sub>2</sub> + VOC sensor	optional
Change power supply	under request

✓ Standard component

✗ Not available

(1): Other filters under request



## 2.4 Technical Specifications

The module is designed to provide a controlled environment suitable for equipment and personnel. The units will be capable for delivery and installation on site without any permanent deformation or failure.

### 2.4.1 Shock-load

Building module units can withstand normal transportation conditions before installation on the site, without deformation or damage.

### 2.4.2 Wind load

The module can withstand non sustained wind speeds up to 111,5km/h (Level 11).

### 2.4.3 Roof load

The module can withstand roof loads up to 145kg/ m<sup>2</sup>

### 2.4.4 Floor load

The module can withstand floor loads up to 1.000kg/m<sup>2</sup> across the entire floor structure. Specific bracing for heavy components such as battery cabinets is provided.

### 2.4.5 External temperature range

Standard: -5°C to 46°C (23°F to115°F)

With Optional Low Temperature Kit: -15°C to 46°C (5°F to115°F)

### 2.4.6 Internal environmental conditions

The internal conditions will maintain ASHRAE 90.1 recommended temperature and humidity ranges.

### 2.4.7 Fire resistance

1 hour fire resistant construction for enclosure walls, roof, and doors is provided.

### 2.4.8 Painting

ISO 40' Enclosures have two primer epoxy and two final polyurethane coats in a RAL 9003 standard color. This surface treatment provides C3 corrosion protection with medium durability (5 to 15 years).

According to ISO 12944 standard, a C3 protection works well in exterior environments with average sulfide oxide (IV) contamination level, inshore areas of low salinity and interior environment with high humidity and certain air contamination.

## 2.5 Mounting Pad support

The module must be placed on a foundation with continuous support for the perimeter walls. The foundation must be level and engineered to support the final total load of the installed and operational module.

## 2.6 Lifting elements

Module is equipped with appropriate lifting points.

- Lift top corner fittings vertically by means of spreaders fitted with hooks, shackles or twist locks
- Lift at bottom corner fitting using slings with terminal fittings at any angles between vertical and 45 degrees to the horizontal.

## 3 Electrical System

Following is the description of the electrical system provided inside the module.

### 3.1 Components

- **Main Input Panel:** (1) 400V three-phase electrical panel, TN-S type, construction type. Panel incorporates 1 main input. The panel will feed all the equipment in the module as well as the condenser for the air conditioners located outside the module. The main panel includes a PM 5100 power meter and Modbus gateway for external access.
- **Uninterruptable Power System:** (1) Symmetra PX 96 kVA/kW Part # SY96K160H with 1 redundant power module
- **Busway Power Distribution:** (1) 160A Canalis Busway KS series, providing power distribution from the UPS to each rack
- **Rack PDU:** (12) AP8853 Rack PDU, Metered, Zero U, 32A, 230V, (36)C13 & (19)C19
- Main Power Cabling:
  - (1) Power line from Main Switch Panel to UPS input
  - Internal cabling for maintenance bypass
  - Connection to Busway Distribution Unit from the UPS section
  - Power connection to the racks from the integrated breakers included in the busway power distribution unit.
  - (6) Power lines to Overhead Air Conditioners
  - (6) Power lines to external condensers
  - Power lines to all internal support equipment
- 
- Lighting:
  - Phillips Light Fixtures providing 300 lux are installed in each aisle in the rack space.
- Emergency lighting:
  - (2) Legrand Exit Sign/Emergency lighting block mounted above each door

## 3.2 Grounding

The module includes an integrated grounding system. The customer will supply a ground from the external system to a grounding bar on the outside of the module. All internal components will be grounded to this bar via the internal electrical system. The module is designed to connect to a TN-S type grounding system.

# 4 Fire Suppression System

The fire protection system is designed to prevent, detect and extinguish possible fires inside the rooms. This will be an automatic system innocuous for people, goods and friendly environment. It will include the following equipments:

- Fire Control Panel
- Smoke Detection System (optional)
- Fire extinguishing system based on IG-55

## 4.1 Fire Control Panel



The fire panel controls the fire detection and extinguishing system. The panel can monitor two distinct areas, can trigger at least 2 levels of alarms, and incorporate a delay to evacuate the room before activating the extinguishing system. The system can also be activated by a manual switch attached to the panel.

This solution will implement a Honeywell Notifier RP1R Supra fire panel with following features:

- Compact and dual microprocessor central
- Easy configuration via micro switches
- Two conventional detection zones for detectors, and a third configurable for auto or manual trigger button
- Stop push button and extinction wait button
- Day / Night function with configurable delay (30 - 300 sec.) And inspection time (1 - 10 min.0
- Possible delays disabled from the keyboard
- Flow switch inputs, low pressure, monitoring door open
- Two extinction circuits, the extinction circuit 2 can be independent for pre-activation
- Countdown timer indicating the seconds left to extinction
- 40 LED display for quick identification the event
- Relays for: warning, alarm in the process of extinction, extinction canceled, extinction circuit failure, and fault relay
- Operating mode: automatic, manual and canceled

- Dry contact input for remote programmable actions as: reset the system, evacuation, mute or delay On / Off
- Removable terminal blocks in all connections
- PC state visualization software with optional remote connection
- Complies with European standards EN54-2/4 and EN12094 / 1:2003
- CE marked

(Additional control panels and features available upon request)

## 4.2 Smoke Detector

Model SD-851E photo-electronic detectors use state-of-the-art optical sensing chambers. The ability to plug these detectors into a variety of base options extends panel compatibility and application flexibility. These detectors are designed to provide open area protection and are only to be used with compatible control panels.

A bicolor LED on each detector lights red to provide a local visible alarm indication, and may also be set to flash green to indicate correct operation of the detector.

## 4.3 Extinguishing system

The automatic fire extinguishing system will be able to extinguish the fire quickly using clean extinguishing agents that don't damage the equipment to be protected. The gas release will be ordered by the fire panel at the second alarm level and once the timeframe expires. A description of the system is provided below

### 4.3.1 IG-55

IG55 is a colorless, odorless, electrically non conductive gas with a density approximately the same as air. (See Physical Properties for additional information).

IG55 is stored as pressurized gas within the cylinder assembly. It is available at storage pressures of 200 bar and 300 bar. When discharged into a protected space, IG55 is clear and does not obscure vision. It leaves no residue and has zero ozone depleting potential and zero global warming potential.

IG55 extinguishes a fire by reducing the residual oxygen concentration to a level that will no longer support combustion.

#### **Features:**

- Natural gas present in the atmosphere
- Suitable for occupied areas
- No toxic or corrosive decomposition products from agent
- Colorless, odorless, compressed gas
- Stored as a gas
- Fogging does not occur when agent is discharged
- Electrically non-conductive
- No residue to clean up after discharge
- Zero ozone depleting potential
- Zero global warming potential

- Included on the U.S. EPA Significant New Alternative Policy (SNAP) rules

**Properties:**

- Chemical Name N2/Ar
- Molecular Weight 33.95
- Boiling Point at 760 mm Hg 310.2°F ( 190.1°C)
- Critical Pressure 602 psia (4,150 kPa)
- Critical Temperature 210.5°F ( 134.7°C)
- Relative Density compared to air 1.18

**Approvals:**

- UL/ULC Listed
- FM Approved

Gas, pipe, pipe fittings, bottle fittings, chrome steel diffusers, stainless diaphragms, manual pulls, system abort button, and protected local labels will be included.

## 5 Monitoring System

The Data Center Module will be provided with an integrated monitoring system that will monitor the status of the module and report the overall health and any alarms associated with the equipment inside the module.

### 5.1 Struxureware DC Expert (optional)

The module can include one Struxureware DC expert appliance and the associated cabling and switches to communicate with all equipment in the module. Struxureware Data Center Expert provides an efficient way for organizations to monitor their company-wide multi-vendor physical infrastructure: power, cooling, security, and environment. Real-time monitoring, user-defined reports and graphs, and instant fault notification and escalation enable quick assessment and resolution of critical infrastructure events that can adversely affect IT system availability. This centralized repository of critical information can be accessed by multiple users from anywhere on the network, creating a consolidated view of the physical data center infrastructure. This open and flexible architecture expands with changing business needs through additional device licenses, add-on surveillance, capacity management and change management modules, and through integration with enterprise and building management systems.

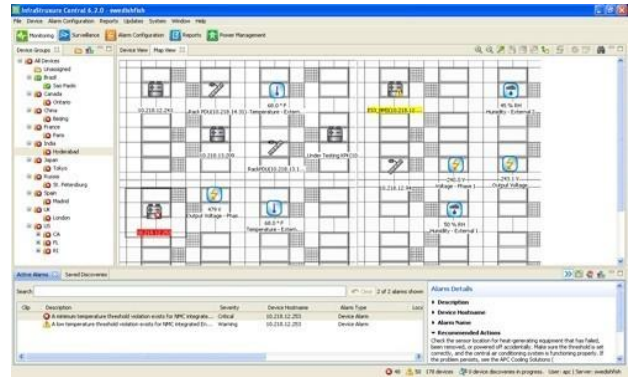
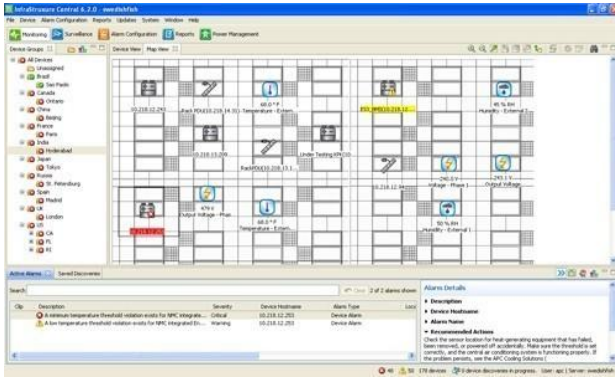

## 5.2 Environmental Monitoring

Each Module includes a Netbotz 570 rack mounted appliance that will monitor the environment and provide security monitoring for the module. The Netbotz 570 is a scalable system which will allow additional sensors and devices to be added to the system to scale to the final needs of the user.



The Netbotz 570 system will monitor the following information inside the module:

- (1) Temperature point mounted on the front of each rack
- (1) Humidity level in the cold aisle
- Status of all the external doors
- Security cameras at each external door location
- Dry contact alarm status on the fire panel

## 6 Internal Module Components and Design

### 6.1 Uninterruptible Power Supply (UPS)

#### Symmetra PX



The Schneider Electric IT Corporation Symmetra PX is a world class, redundant, scalable, power protection system designed to cost effectively provide high levels of availability. Seamlessly integrating into today's state-of-the-art data center designs, the Symmetra PX is a true modular system. Made up of dedicated and redundant modules--power, intelligence, battery and bypass, all engineered into a design that is easily and efficiently serviceable, this architecture can scale power and runtime as demand grows or as higher levels of availability are required. Symmetra PX serves as the core power train that drives Schneider Electric IT Corporation InfraStruxure® systems for small and medium data centers but can also power individual "zones" of larger data centers. Highly

manageable, the Symmetra PX features self-diagnostic capabilities and standardized modules which mitigate the risk of human error resulting in increased overall data center reliability.

### 6.2 Racks

#### NetShelter SX

APC NetShelter rack enclosure maximizes flexibility with a progressive, non-proprietary feature-set as well as an extensive line of scalable accessory products to address current needs and adapt to future technology trends. APC NetShelter® rack systems provide a progressive feature-set available in a vendor-neutral rack environment while allowing the user the flexibility to quickly adapt to emerging trends. Available in a variety of heights and widths, NetShelter racks and enclosures support can adapt of any type of applications.



### 6.2.1 Cable Management

The solution includes all overhead cable management accessories (power and data cable). The module includes an E-chain system that manages the cables as they enter the equipment rack. The E chain system will move with the racks as they are moved on the rail system (described below). Wire mesh cable tray is also provided in the appropriate location to carry cable within the module.



The features of the e-chain are the following:

- Sideband and frame construction with large anti-friction single pin
- Frame opening from inner radius or from outer radius
- Vertical separators are available
- This standard 35 mm chain offers very high load capacities, despite its compact construction

### 6.2.2 Rack Power Distribution

APC Metered Rack Power Distribution Units (PDUs) provide active metering to enable energy optimization and circuit protection. User-defined alarm thresholds mitigate risk with real-time local and remote alerts to warn of potential circuit overloads. Metered Rack PDUs provide power utilization data to allow Data Center Managers to make informed decisions on load balancing and right sizing IT environments to lower total cost of ownership. Metered Rack PDUs include real power monitoring, a temperature/humidity sensor port, locking IEC receptacles, and ultra low profile circuit breakers. Users can access and configure Metered Rack PDUs through secure Web, SNMP, or Telnet Interfaces which are complimented by Struxureware Centralized Management platforms.





### 6.2.3 Rail System

Schneider Electric has designed a new option for its products allowing rack movement. Rack movement allows easier access to the front and rear of the rack and mounted equipment.

There are two rails per rack. The rail guide system main components are:

- Rack fixations
- Telescopic rail
- Floor fixation

Two wheels in the middle of the rack help the smooth movement of the rack. However, the weight is mainly supported by the telescopic rails. Two hasps fixed on each telescopic rail complete the system, setting the rack in its mid position.

Our standard rail system, with 2 telescopic rails, is designed for a maximum load of 800 kg (1780 lbs.).



### 6.3 Room Power Distribution

Canalis KN is low voltage trunking busbar system for amperages up to 160A. A single busway distribution bus is provided to distribute power from thUPS provided in the module to each equipment rack (a 2N power distribution busway can be optionally provided.) The Canalis busway system is a modular and upgradeable system, with quick assembly and installation. Canalis components are light and easy to handle and expose no live parts to the user for a safe and convenient experience



### 6.4 Cooling

Each module includes (6) Mitsubishi Electric SPEZ 250 fan coil cooling units. Each unit utilizes a DX refrigerant coil with an external condenser mounted on the exterior of the module. Refrigerant piping between the main unit and the condensers is provided. The unit is oriented above the equipment racks and takes hot air in from the rear of the racks and supplies cold air to the front.



## 7 Exclusions

The following list gives the limit of our scope of supply. All works listed hereafter are excluded from this proposal.

### **General:**

- Any item not specifically listed in the proposal
- Freight to the final site
- Unloading of the module into its final position
- Project management services

### **Civil works:**

- Any outdoor and indoor civil works (e.g. trenches, preparation of foundations, concrete slabs, fireproof walls, doors, holes, stairs...)
- Any opening or drilling in the building existing walls and roof
- Any scaffolding, builders work or allied tradesman work
- Any ceiling or overhead plenum
- Installation of condensers on external slab
- Attachment of piping between condensers and module
- Any steps or ramps required for doorways

### **Data cabling:**

- Any IT cabling and fiber optics installation

### **Electrical cabling:**

- Any electrical installation work outside the prefabricated building solution
- Any digging, trenches and soil preparation for fuel tank and piping network installation
- The supply and installation of the incoming LV electrical supply from the gensets
- The supply and installation of the incoming LV electrical supply from the normal source

### **Electrical equipment:**

- Emergency gensets including fuel tanks