

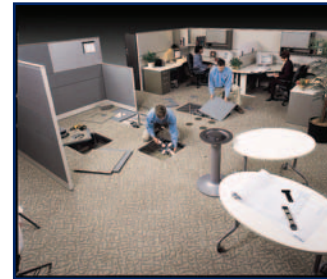

Owner's Manual

Maintenance, Safety and Guidelines



Office Environments



Equipment/Telecom



Clean Rooms

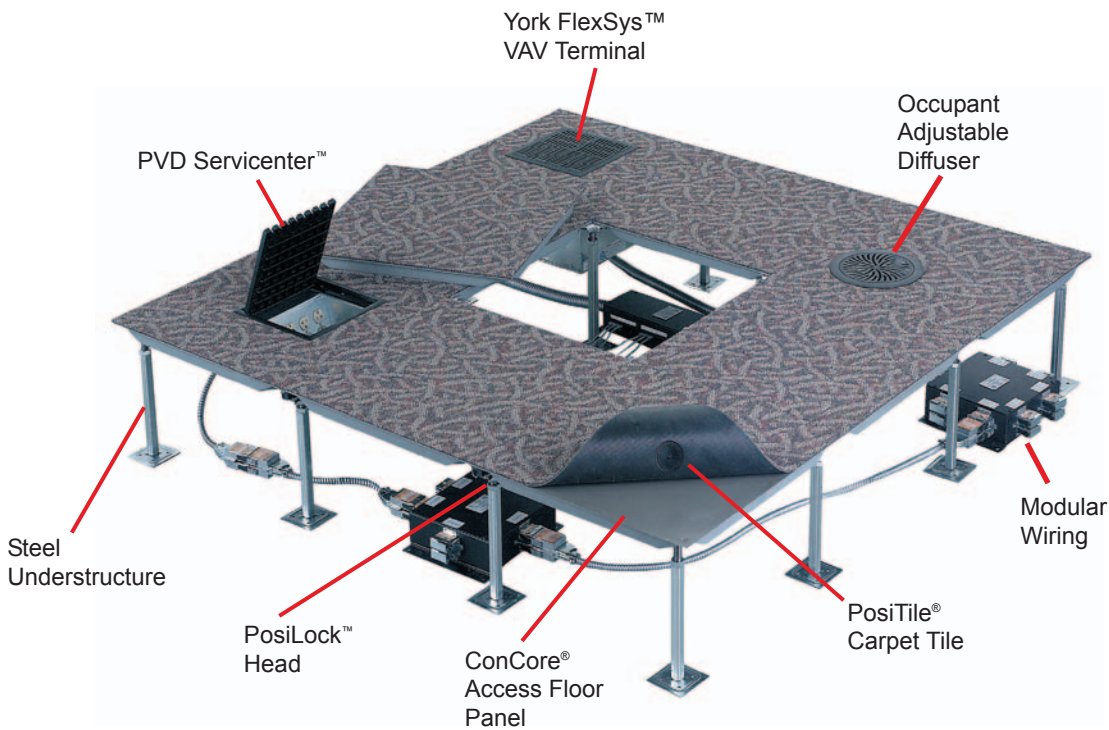

Table of Contents

I. Care and Use of the Tate Access Floor System	
Moving Precautions	1
Adjustments fo Floor system	2
Removal and Reinstallation	2
Special Precautions	2
II. Floor Coverings	
PosiTile®	3
Conductive and Static Dissipative	3
Standard High Pressure Laminate	4
III. Panel Cutting Procedures	
Rectangular Cutouts, External & Internal	5
Round Cutouts	5
Installing	6
Safety Requirements	6
IV. Electrical Guidelines	
Floor Static Control, Computer Rooms	7
Grounding, Bonding & Electro- Static Discharge Control	7
V. Test Standards	
Static Load	8
Dynamic Loads	8

Care and Use of the Tate Access Floor System

Access floor systems are supplied and installed in conformance with the requirements set forth by individual project specifications and approved submittal documents. It is important to clearly understand the design capabilities of the Tate access floor system as installed in specific projects.

Equipment Moving Precautions

The access floor must be protected from overloads and circumstances that exceed its specifications. Movement of heavy loads and equipment may require protection of the floor system through the use of plywood or other suitable load-distributing materials.

- The All Steel panel is a hollow steel panel designed primarily for static loads. Please consult your Tate representative before heavy loads are exerted on the floor.*
- The ConCore® panel, similar in design to the All Steel panel, is filled with a structural cementitious material. It has excellent static and rolling load capabilities.*
- The Floating Floors® by Tate panel is a diecast aluminum panel with excellent static and rolling load capabilities. It is designed to meet the needs of today's high-tech environments such as clean rooms and laboratories. *

** Please contact an authorized Tate dealer or call the Tate Technical Hotline at 1-800-231-7788 for procedures to follow when wheel sizes and loads differ from those identified in Tate product specifications.*

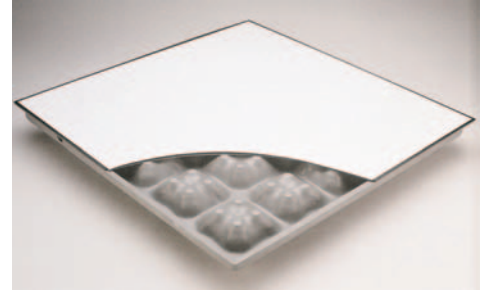

All Steel Panel

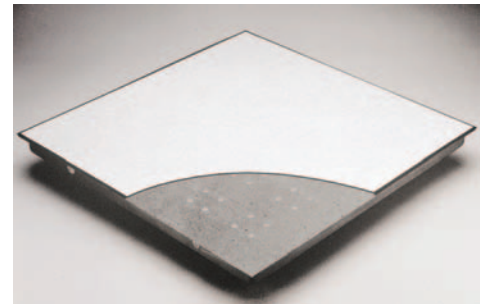

ConCore® Panel

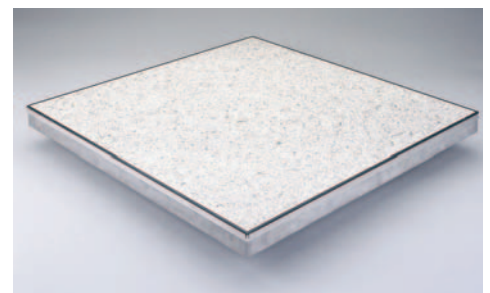

Floating Floors® Panel

Care and Use of the Tate Access Floor System

Adjustments to the Floor System

It is advisable for the floor owner or owner's representative to get a demonstration of the use of pedestal height adjustment and leveling mechanism by a representative of the floor provider before making adjustments to the system. Periodically inspect the installed floor and make adjustments for the following conditions:

Rocking Panels

1. Check to assure that pedestal head gaskets are positioned correctly and/or stringers are securely fastened. Make sure that no carpet pile or dirt prevents panels from seating correctly.
2. Adjust the pedestal leveling nut after confirming that the pedestal is sitting flat on the subfloor.
3. For persistent problems with tiled panels, try rotating the panels by 90 degrees.

Tipping at Perimeter Panels

Tipping generally occurs when the perimeter panel is improperly supported. Adjust the leveling nut on the pedestal support, raising or lowering the pedestal head until the panel sits firmly on the pedestal head or stringer.

Panels with Factory-Laminated Carpet

1. Check to see that the carpet grain runs in the same direction for all panels; arrows on the bottom of the panels should all be facing the same direction. Rotate panels as necessary to obtain uniform grain direction.
2. Trim any loose tufts of carpet.
3. Check for trapped yarn fiber at the edges of the panel. Use an approved lifting device to remove the panel, then remove the trapped yarn fiber. Use a carpet shoe-horn when reinstalling panels to avoid pile trapping and trim damage.

Special Precautions

1. The use of screwdrivers, pliers or other objects to pry or lift panels should be prohibited.
2. Do not disturb the level adjustment of the support pedestals and position of the stringers while floor panels are out of the floor system.
3. When panels with factory-laminated carpet are reinstalled, use a carpet shoehorn to ensure that carpet pile is not trapped.
4. When reinstalling panels with trim, use a carpet shoehorn to ensure the life of the trim.
5. Always make a final check to see that panels are correctly in place, level and secure.

Removal and Reinstallation of Panels

When accessing underfloor space, remove only those panels directly over the area of concern. Remove the first panel with the appropriate lifting device. Place the lifter in the corner of the panel and lift up vertically. Once the panel is far enough above the plane of the adjacent panels, remove the panel by hand. Adjacent panels may be lifted as necessary by hand.

Types of Lifting Devices

Suction Cup Lifter

for use on bare panels and panels with a hard surface floor covering.



Claw Lifter

for use on panels with cut pile carpet laminated to the panel.

Velcro Lifter

for use on panels with level loop carpet laminated to the panel.

Floor Coverings

PosiTile®

PosiTile carpet tiles are precisely cut to fit the modular 2'x2' size of Tate's ConCore® access floor panels. Each tile has positioning buttons that precisely align with holes in the top of each floor panel. This eliminates the need for adhesives, except at perimeter locations.

Installation

When installing carpet tiles, the access floor surface should be free of dirt, debris and excessive dust. Remove plastic plugs from panels' surface before installing PosiTile® carpet tile.

Perimeter Tiles

Carpet tiles can be easily cut to fit perimeter locations and areas around columns. If positioning buttons are eliminated when tile is cut, adhere carpet with a releasable adhesive or double faced tape.

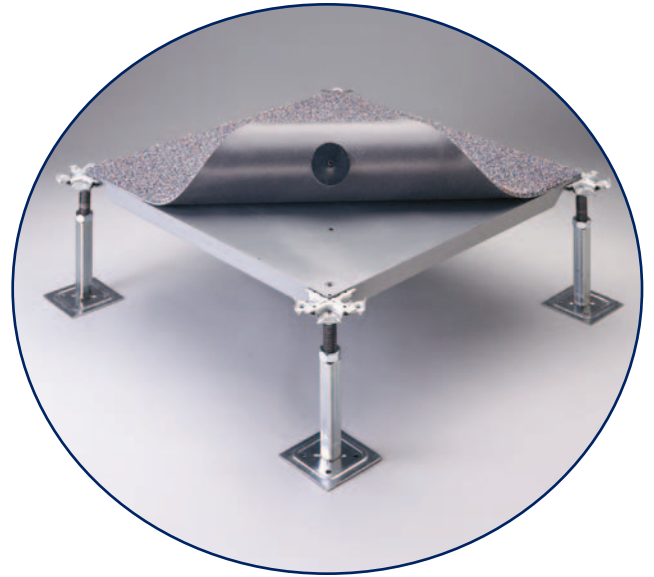

Conductive and Static Dissipative

The access floor covered with either conductive or static dissipative vinyl tile is designed for years of service by following these guidelines:

Damp Mopping for Conductive and Static Dissipative Vinyl Tile

When light soiling is widespread, use this damp-mopping procedure:

1. Sweep or vacuum floor thoroughly.
2. Damp-mop with warm water and mild multipurpose ammoniated floor cleaner.
3. Dip sponge mop into warm water, wring out thoroughly, and push sponge across the floor, pressing hard enough to loosen surface dirt.
4. Damp-mop a small area at a time, wringing the sponge out frequently.
5. When damp-mopping a large floor, change water frequently.
6. A sponge mop with a nylon scrubbing pad attached to the front edge is recommended.
7. Rinsing is important. Although detergent directions may state rinsing is unnecessary, any detergent film left on a floor will attract dirt.
8. Ideally, use separate sponge mops for cleaning and rinsing.

DO:

1. Keep floor clean by damp-mopping with a neutral cleaner.
2. Protect from tracked in sand and chemicals by providing mats at entrances.
3. Rotate panels between high- and low-traffic areas.
4. Use a diluted commercial stripping agent on heavily soiled areas.

DO NOT:

1. Flood with liquid, or use anything other than a damp mop. Large amounts of water can weaken adhesive and cause delamination.
2. Use strong abrasives or scrapers to remove stains.

Standard High Pressure Laminate

The access floor covered with high pressure laminate floor tile is designed for years of service with a minimum of care and cleaning. Gain maximum life from this floor surface by following these guidelines:

Damp Mopping for Standard High Pressure Laminate Floor Tile

When light soiling is widespread, use this damp-mopping procedure:

1. Sweep or vacuum floor thoroughly.
2. Damp-mop with warm water and mild multipurpose ammoniated floor cleaner.
3. Dip sponge mop into warm water, wring out thoroughly, and push sponge across the floor, pressing hard enough to loosen surface dirt.
4. Damp-mop a small area at a time, wringing the sponge out frequently.
5. When damp-mopping a large floor, change water frequently.
6. A sponge mop with a nylon scrubbing pad attached to the front edge is recommended.
7. Rinsing is important. Although detergent directions may state rinsing is unnecessary, any detergent film left on a floor will attract dirt.
8. Ideally, use separate sponge mops for cleaning and rinsing.

DO:

1. Keep floor clean by damp-mopping with a mild multi-purpose ammoniated floor cleaner.
2. Protect from tracked in sand and chemicals by providing mats at entrances.
3. Rotate panels between high- and low-traffic areas.
4. Use a non-flammable organic solvent on soiled spots.

DO NOT:

1. Use wax seal—it is not necessary.
2. Flood with liquid, or use anything other than a damp mop. Large amounts of water can weaken adhesive and cause delamination.
3. Use strong abrasives or scrapers to remove stains.



Panel Cutting Procedure

Guidelines for Cutting Panels

When it is necessary to penetrate and/or modify the floor panels, follow these guidelines:

1. Use proper equipment and follow the equipment manufacturer's recommended safety precautions.
2. Use protective trim around exposed edges for cutouts within a panel and cutouts through the panel edge.

Rectangular Cutouts, External & Internal

Panels with cutouts extending to the edge of the panel can be cut with a handsaw. Cutouts inside the perimeter of the panel can be cut with a heavy-duty handheld reciprocating saw. **A cutout should be at least 3 inches from the panel edge to maintain a reasonable degree of structural integrity.**

Use bi-metal saw blades with approximately 14 teeth per inch. (Cutout sizes for Tate accessories are shown in figure 15).

For a rectangular inside cutout:

1. Lay the cutout on the panel (see Figure 16).
2. Drill pilot holes in two opposite corners. Be sure the holes are large enough for the saw blade to pass through without binding.
3. Cut out the hole.
4. Deburr all cutouts made for grills or electrical boxes where no trim will be used.

Round Cutouts

Round or grommet cutouts can be made with a hole saw up to 6" in diameter. A drill press is recommended for this operation. Use a very slow-speed heavy-duty drill with a bi-metal cutting hole saw blade. With a hand-held drill, pre-drill a hole at the center of the cutout location. For round holes larger than 6", lay out the circle on the panel. Drill one entry hole along the edge of the circle just inside of the line and cut out the panel with a reciprocating saw, then deburr all sharp edges.

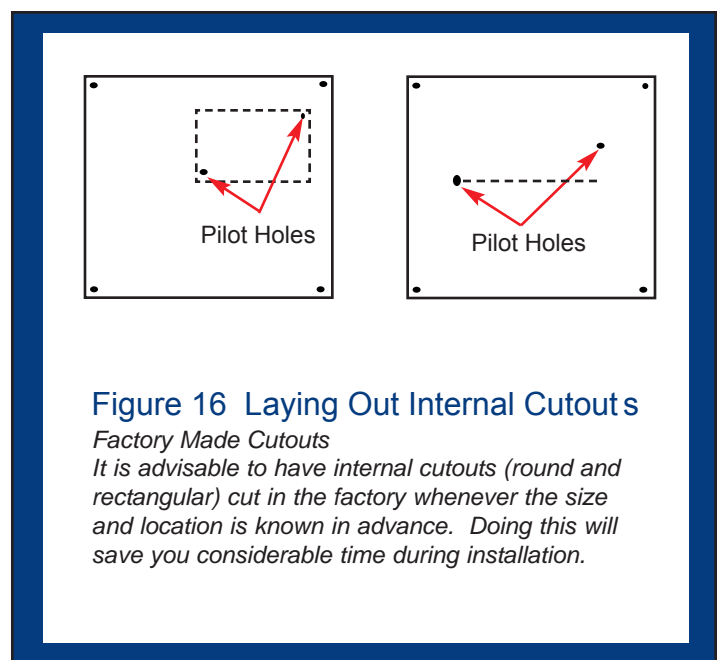
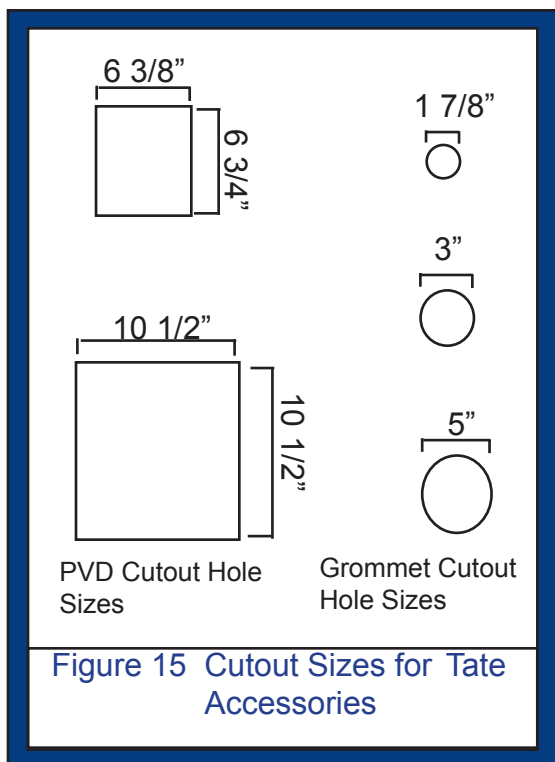

Installing Protective Trim around Cut Edges

All rectangular cutouts to be used as a passageway for cables or other services must have protective trim along the cut edges. Tate's cable cutout trim components include universal cutout trim in 4-foot lengths, molded corners and screws. An optional foam plenum seal is available to seal the opening.

Before cutting the trim, note how the molded corners hold the trim in place. Cut the vinyl trim pieces straight at each end so that the ends can fit under the corners (figure 17).

Secure each molded corner in place with a screw fastened into the panel. If the cutout extends to the edge of the panel, attach the trim near the edge of the panel without molded corners. To do this, attach the straight piece directly to the panel with a pop (blind) rivet or screw. If a screw is used, countersink the screw in the trim piece.

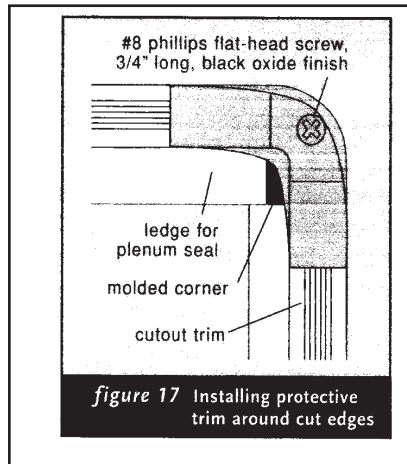

Safety Requirements for Panel Cutting

When using a hand-held heavy duty (industrial) reciprocating saw, follow the guidelines below:

- a) Use a bench or worktable to cut the panels, i.e. a B&D Workmate bench with clamps.
- b) Work in a well-lighted area
- c) Be sure tools are properly grounded and dry.
- d) Use the correct saw blade (14 to 20 teeth per inch metal cutting blade).
- e) Be sure the entry hole is large enough to start the saw blade without binding.
- f) Use common sense to avoid personal injury
- g) Always use safety equipment including:
 - Ear protection
 - Safety glasses and full face shield (clear plastic)
 - Long sleeve shirt or sleeve protectors
 - Lightweight work gloves for protection from sharp metal edges and hot saw dust)
 - Steel toe safety shoes or boots

Supporting a Cut Panel:

When it is necessary to retain the design load capacity of a panel after it has been cut, an effective solution is to use additional pedestal supports. Guidelines for the number and location of additional supports are outlined below:

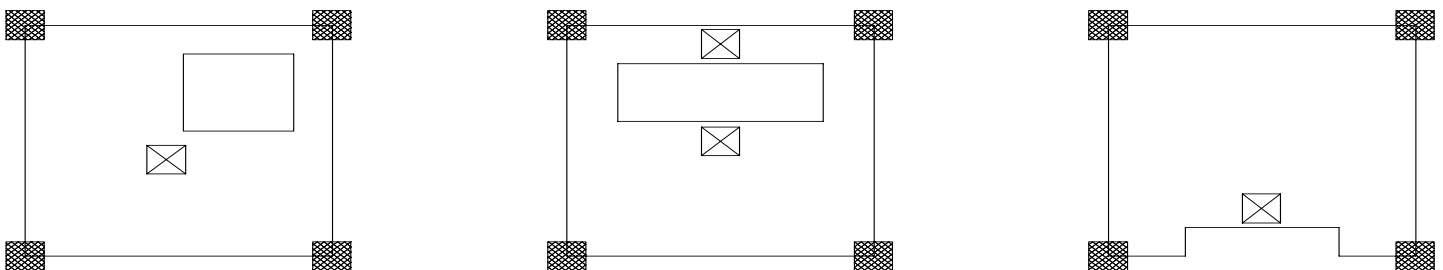

-  = ADDITIONAL SUPPORT PEDESTAL
 = SUPPORT PEDESTAL

Electrical Guidelines

Floor Static Control for Computer Rooms

Standard HPL coverings are classified as antistatic coverings and provide the necessary static protection for most computer rooms. According to industry standards, to ensure a proper balance between insulation and conductivity in anti-static floor coverings, the electrical resistance range of the floor covering should range from 150,000 to 20 billion ohms. Standard high-pressure laminates offered by Tate adhere to these guidelines.*

Static buildup and discharge can be minimized by

- providing a conductive path to ground from a metallic raised floor structure, including the metal panels;
- ensuring that a maximum resistance for the flooring system is 2×10^{10} ohms, measured between the floor surface and the building (or an applicable
- ground reference). Flooring material with a lower resistance will further decrease static buildup and discharge. For safety, the floor covering and flooring system shall provide a resistance of not less than 150 kilohms (150,000 ohms) when measured between any two points on the floor space 1m (3 ft) apart.

Maintenance of antistatic floor coverings should follow the individual supplier's recommendations.

**Based on IBM Resistivity Range, from the IBM General Information Manual, Second Edition, publication numbers GC22-7072-1, dated January 1987.*

Test Standards

There are no industry standards for access floor loading performance. However, The Ceilings & Interiors Systems Construction Association (CISCA) has published *Recommended Test Procedures for Access Floors* for concentrated, ultimate, rolling, stringer, pedestal axial and pedestal overturning moment loads. Tate utilizes CISCA guidelines in the development of all test procedures.

Static Loads

Concentrated

These loads are applied on a small area of the panel surface, i.e. from a deskleg or computer frame. The concentrated load is applied on a 1"x1" indenter, and deflection is measured at the top surface under the load. Permanent set (rebound) is measured after the load is removed.

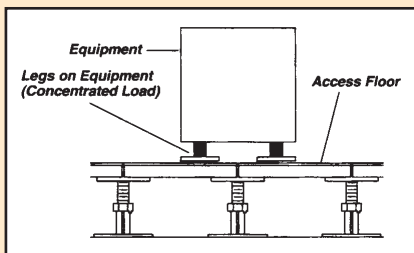

Uniform

Uniform loads, expressed in pounds per square foot, are applied over the entire surface of the panel, i.e. a file cabinet.

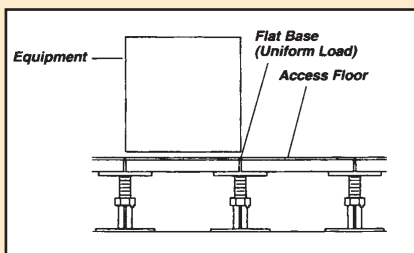

Ultimate

These loads are reached when the panel has failed structurally and cannot accept additional load.

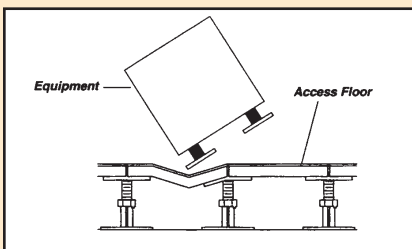

Dynamic Loads

Rolling

These loads are applied by wheeled vehicles carrying loads across the floor, i.e. chair casters, pallet jacks, and electronic mail carts. Dynamic loads are defined by wheel size and hardness, weight of vehicles, contents, and number of passes.

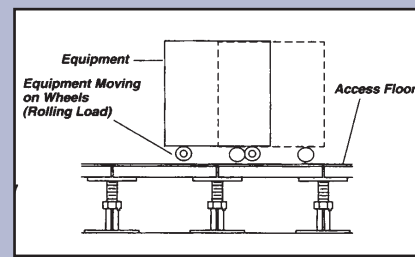

Impact

Impact loads are achieved by dropping objects on the floor, i.e. a box of computer paper dropped from waist height. Impact loads are defined by weight, impact surface area and distance dropped.

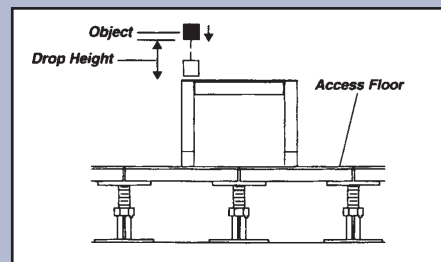

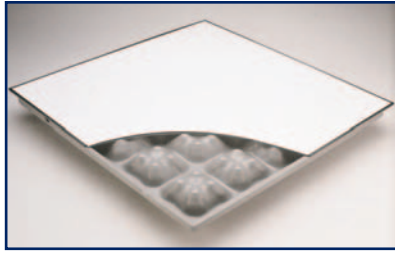

All Steel Panel

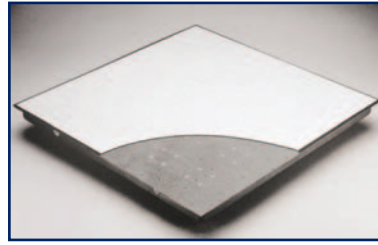

ConCore® Panel

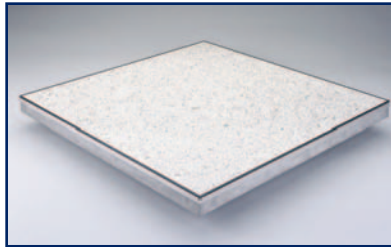

Floating Floors® Panel



PosiTile® Panel



Corporate Headquarters
Tate Access Floors, Inc.
7510 Montevideo Road
Jessup, MD 20794
www.tateaccessfloors.com
Tel: 410-799-4200
Fax: 410-799-4207

Production Facilities
Tate Access Floors, Inc.
7510 Montevideo Road
Jessup, MD 20794
Tate Access Floors, Inc.
52 Springvale Road
Red Lion, PA 17356



Tate® Building Technology Platform®, ConCore®, PosiLock® and PosiTile® are registered trademarks of Tate Access Floors, Inc.
PVD Servicer™ is a trademark of Tate Access Floors, Inc. © 2001 Tate Access Floors, Inc.

